



## FIRST TIME INSTALLATION

\* REMOVE PARTS FROM INSIDE THE PACKAGE AND CHECK THEM ALL

\* CONTACT YOUR DEALER IF ANY PART IS MISSING OR DAMAGED

\* USE THE EQUIPMENT SPECIFIED FOR INSTALLATION

### ASSEMBLY INSTRUCTIONS (ROOF RACK)

Product Code: MC01004

### COMPATIBLE VEHICLES

SKD YET (5L) SUV 09-17

### PACKAGE INCLUDED

1-	TURTLE AIR1 CHASSIS	4
2-	5MM ALLEN WRENCH	1
3-	CLOTH KEYCHAIN	1
4-	TURTLE AIR1 UPPER RUBBER	4
5-	C14	4
6-	M6x30 INBUS BOLT (Max. 5 Nm)	4
7-	M6 1/2 WASHER	4
8-	M6x15 INBUS BOLT (Max. 5 Nm)	8
9-	M6 WASHER	8
10-	M6 SPEEDNUT	4

ZIPLOCK BAG

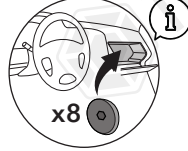
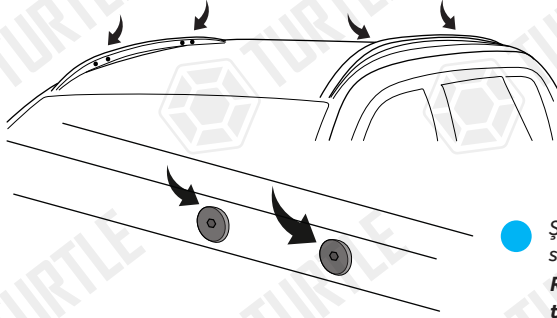

Şekilde gösterilen plastik kapakları sökünüz ve saklayınız.

Remove the plastic caps shown in the figure and save them.

Klipsi metal demirin üst kısmına yerleştiriniz.  
Place the clips top of the metal bracket.

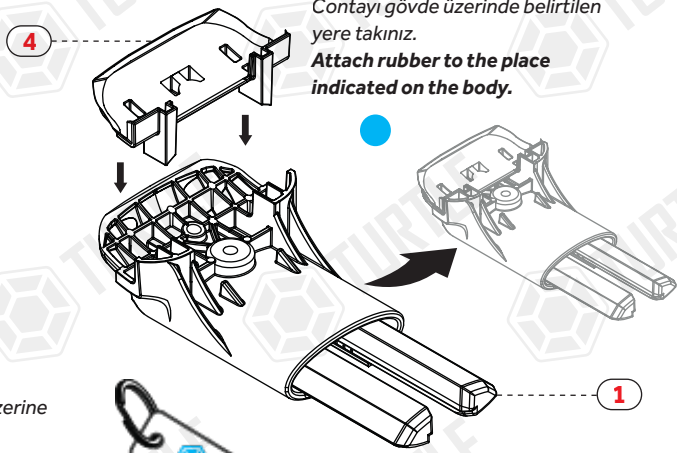
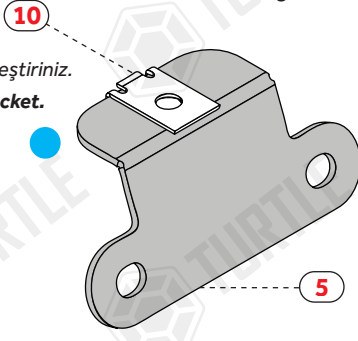

Contayı gövde üzerinde belirtilen yere takınız.  
Attach rubber to the place indicated on the body.

Civata ve pul yardımı ile bağlantı aparatının üzerine Turtle® Air şasiyi yerleştiriniz.  
To place Turtle® Air chassis and tight bolt with washer top of the bracket.

Max. 5 Nm

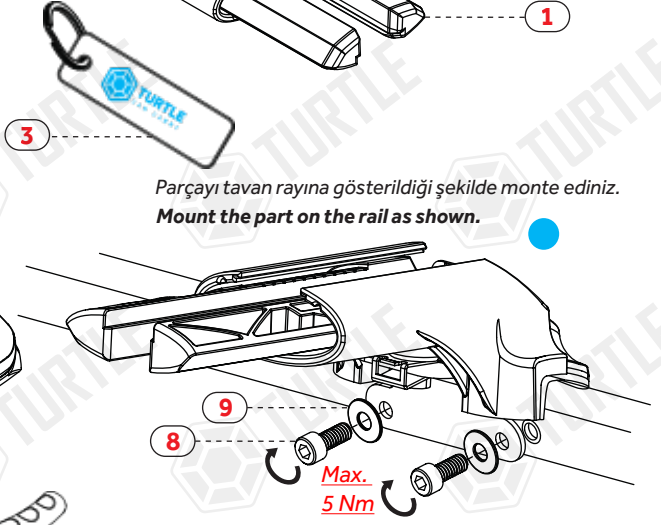
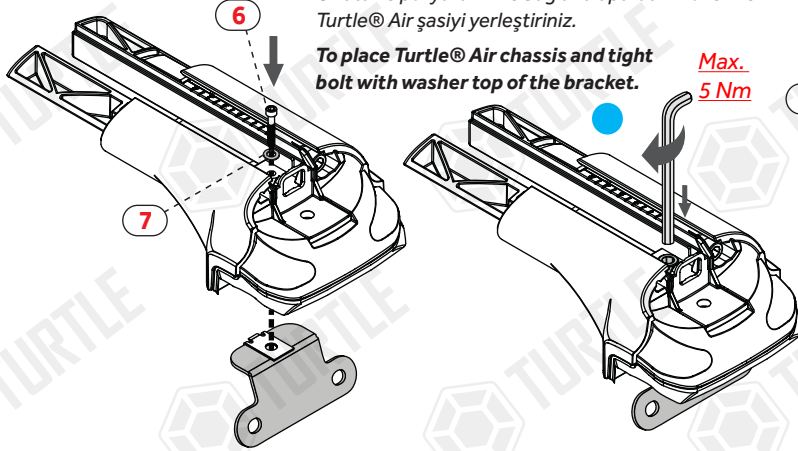

Parçayı tavan rayına gösterildiği şekilde monte ediniz.  
Mount the part on the rail as shown.

Profilleri ortaldıktan sonra yatay sabitleme civatalarını sıkınız.

After centering the profiles, tighten the horizontal fixing bolts.

Max. 5 Nm

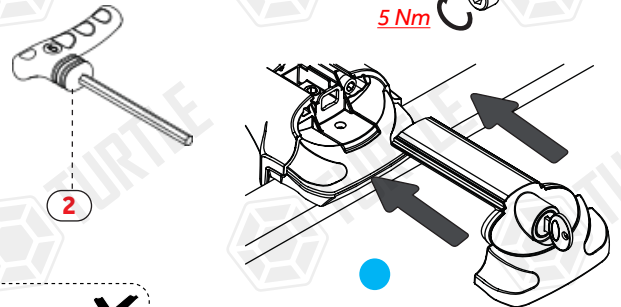
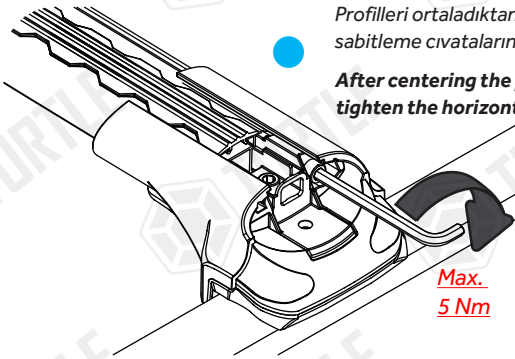

Max. 5 Nm

Turtle® Air-1 kapağını kapatınız ve kilitleyiniz.  
Close the Turtle® Air-1's cap and lock.

80 Km/h  
50 Mph

130 Km/h  
80 Mph

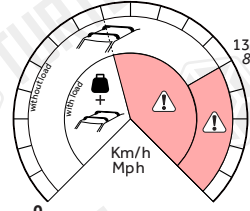

Max. Load  
75kg

LONG FOR FRONT  
SHORT FOR REAR

\* Kullanım amacı; Aracın bagajı yeterli olmadığı durumlarda araç tavanında yük ve eşya taşımak.

\* Purpose of usage; Carrying cargo and goods on the vehicle's roof when the vehicle's trunk is not sufficient.